

Valve Regulated Type Stationary Lead-Acid Battery

FVL SERIES

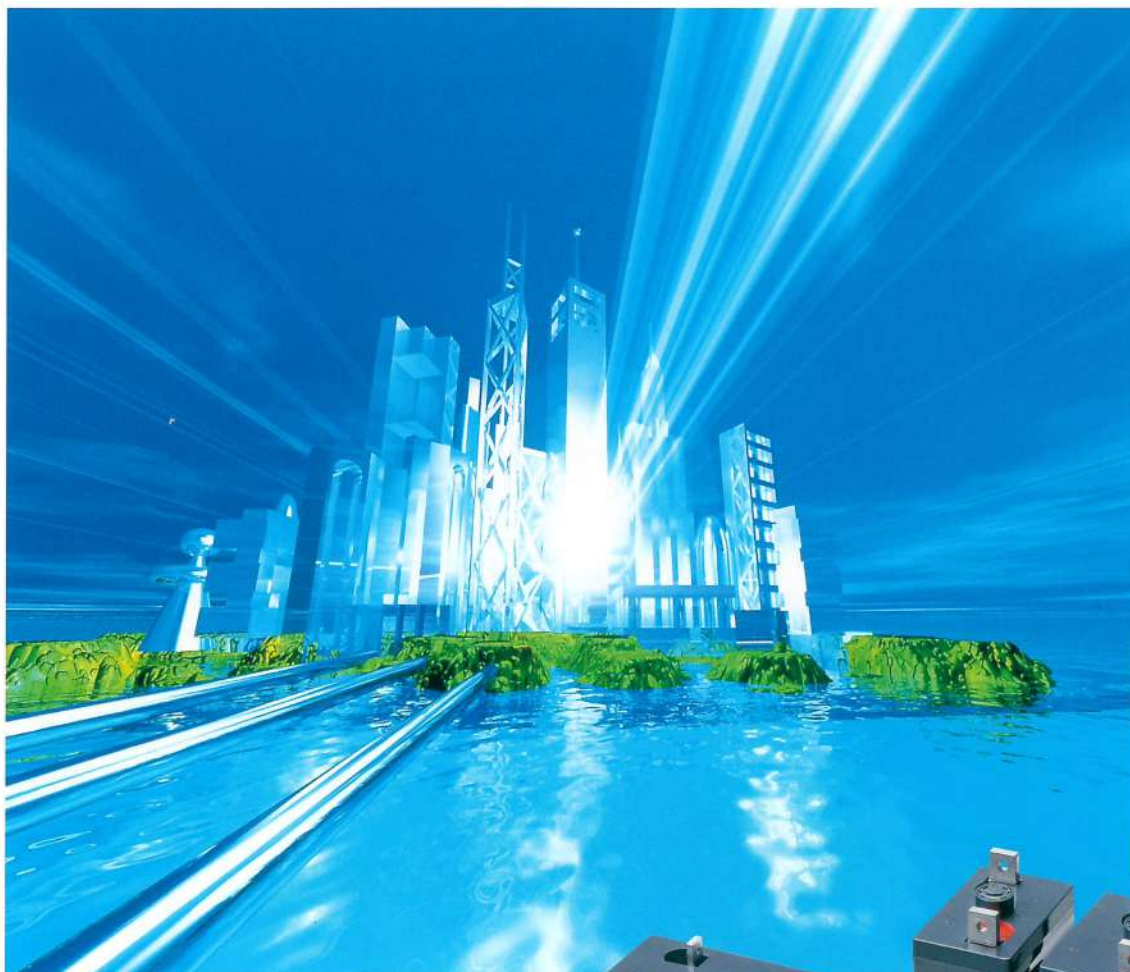

FVL SERIES

In advanced information society, in which is maintained with computerized system, uninterrupted power should be necessary in 24 hours.

We, The Furukawa Battery Co., Ltd., have been contributing with supplying of reliable stationary batteries to cope with such societal demand.

"FVL Series" is a Valve regulated type stationary lead-acid battery which was developed to realize higher performance and 13~15 years of longer life.



Features

- With using of grid alloy and active materials that were improved with advanced technology, "FVL Series" has an expected life of approx. 13~15 years(at 25°C of ambient temperature, 0.1C(A)discharge).
- Longer life shall bring cost reduction on actual running.
- "FVL Series" requires no additional water during the service life.

Construction

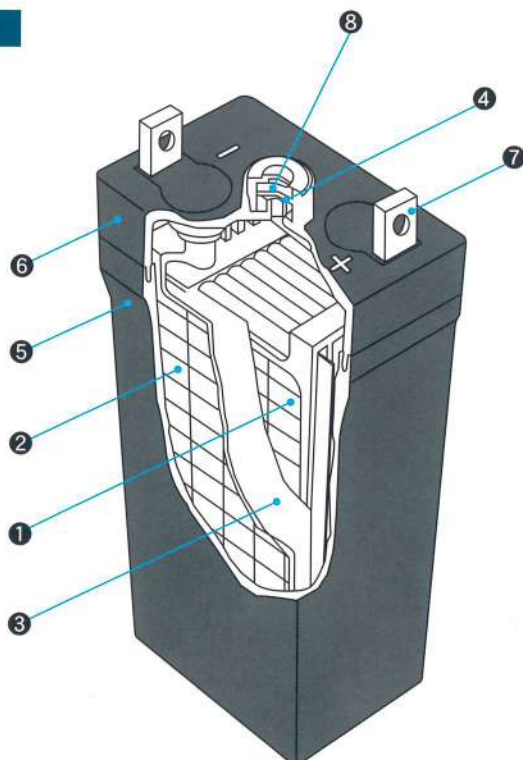

	Part Name	Material
①	Positive plate	Lead-Calcium alloy Lead Peroxide (PbO ₂)
②	Negative plate	Lead-Calcium alloy Sponge Peroxide (Pb)
③	Separator	Glass fiber unwoven fabric
④	Vent valve	Synthetic rubber
⑤	Container	ABS resin
⑥	Cover	ABS resin
⑦	Terminal	Lead alloy
⑧	Filter	Ceramic

Sealing Principle

In the last stage of charging, lead acid battery generates oxygen gas from the positive plate and hydrogen gas from the negative plate by electrolysis of water in the electrolyte.

Sealed battery requires control of gas generation or absorption of gas in the battery.

Sealing principle of gas recombination on negative plate is as follows.

- 1 A special gas permeable material (fine glass fiber unweaved fabric) is used for the separator and the amount of electrolyte is controlled to the minimum so that the gas can permeate between the positive and negative plates.
- 2 Oxygen (O_2) gas is generated from the positive plate in the last stage of charging and the O_2 gas reacts with the spongy lead (Pb) of the negative plate and turns into lead monoxide (PbO).

Note: Charged active material (Pb) of the negative plate can easily be oxidized, that means it has a property to easily absorb oxygen gas.

- 3 Lead monoxide (PbO) in the negative plate reacts immediately with the electrolyte (H_2SO_4) and turns to lead sulfate ($PbSO_4$) and water (H_2O) allowing the negative plate to discharge.

In other words, the negative plate discharges partially

through absorption of oxygen.

- 4 Continuation of charging turns the lead sulfate ($PbSO_4$) to spongy lead (Pb) but again turns to a partial discharged state by oxygen.
- 5 The negative plate in the last stage of charging is also discharging at the same time and maintains always a balance in a state prior to hydrogen gas generation and there, the negative plates never generate hydrogen.
- 6 On the other side, since the oxygen generated in the positive plate is absorbed to the negative plate and disappeared, it is in appearance the same state in this battery as no electrolysis of water. Accordingly, this prevents the loss of water in the electrolyte.
- 7 Although the internal pressure of the battery is increased to some extent, the strength of container is designed with sufficient safety. Even when the battery is overcharged exceeding the gas absorption capacity to increase the internal pressure, safety measure is kept by the operation of the safety valve.
- 8 The safety valve can also prevent oxidation of the negative plate by air from outside and serves to control a spontaneous evaporation of water.

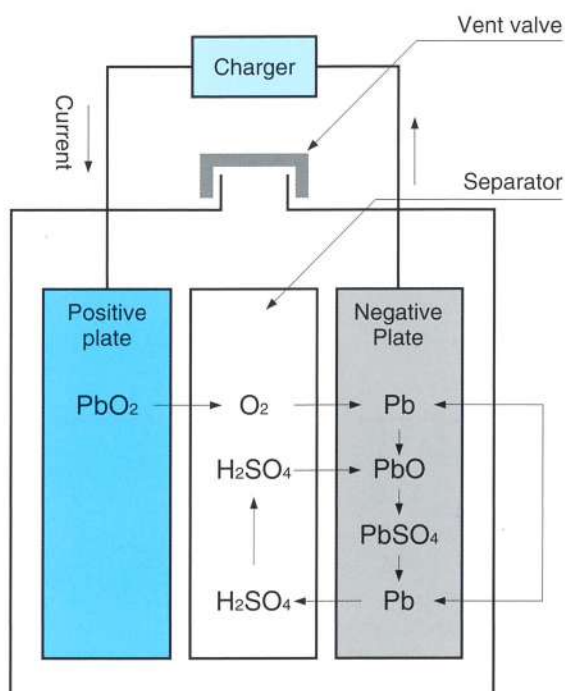

Gas generating reaction in positive plate:

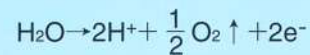

Gas absorbing reaction in the negative plate:

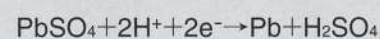
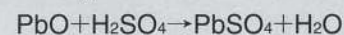
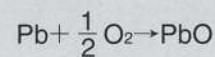

Cell Specification

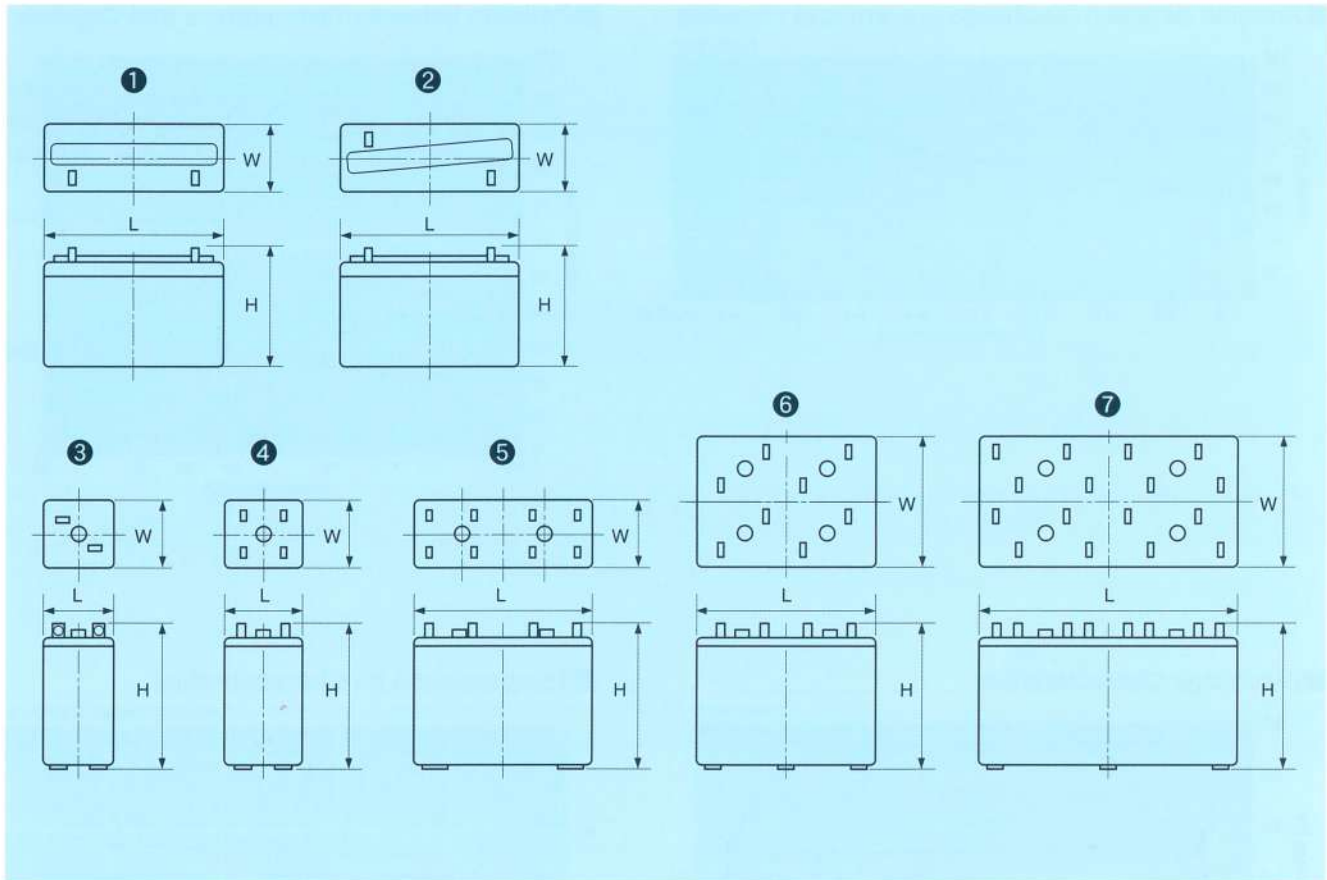

Type	Nominal Voltage (V)	Rated Capacity (Ah)		Outer Dimension (mm)			Approx. weight Kg	Fig.
		10-hour rate	1-hour rate	Hight	Width	Length		
FVL-50-12	12	50	32.5	220	128	363	20.5	①
FVL-100-6	6	100	65	220	128	345	20	②
FVL-150	2	150	97.5	365	170	106	12.5	③
FVL-200	2	200	130	365	170	106	15.5	③
FVL-300	2	300	195	365	170	150	22	③
FVL-500	2	500	325	365	171	241	36	④
FVL-1000	2	1000	650	365	171	471	72	⑤
FVL-1500	2	1500	975	375	337	476	113	⑥
FVL-2000	2	2000	1300	375	337	476	143	⑥
FVL-3000	2	3000	1950	375	340	696	216	⑦

Required Capacity (Ah/10HR)	Combination
50	FVL-50-12
100	FVL-100-6
150	FVL-150
200	FVL-200
300	FVL-300
400	FVL-200×2
500	FVL-500
600	FVL-300×2
700	FVL-200+FVL-500
800	FVL-300+FVL-500

Required Capacity (Ah/10HR)	Combination
900	FVL-300×3
1000	FVL-1000
1100	FVL-300×2+FVL-500
1200	FVL-200+FVL-500×2
1300	FVL-300+FVL-500×2
1500	FVL-1500
2000	FVL-2000
2500	FVL-1000+FVL-1500
3000	FVL-3000

Characteristics

● Relation between Discharge current and Capacity

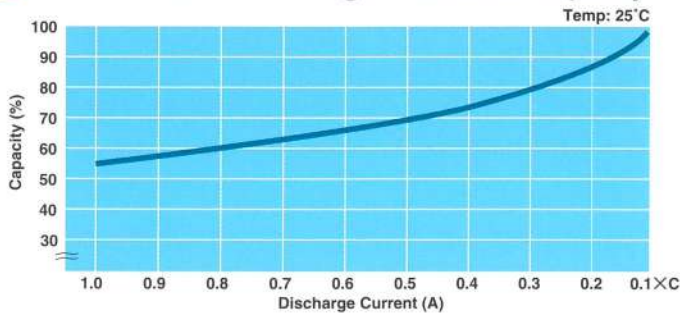

● Relation between Temperature and Capacity

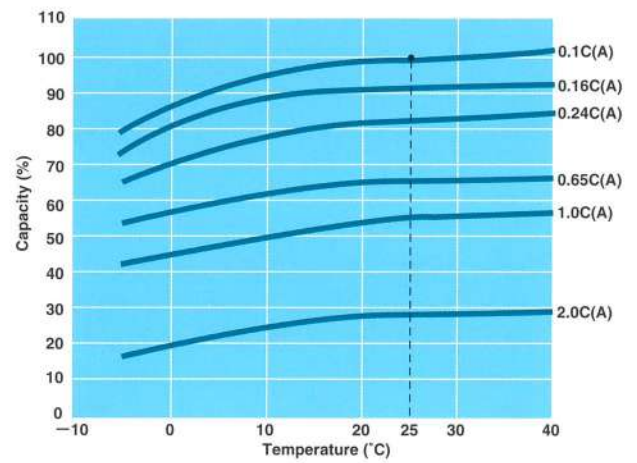

● Discharge Characteristics

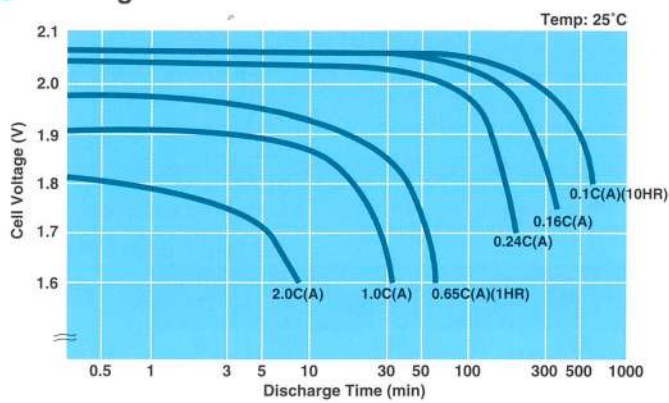

● Temperature-Life Characteristics

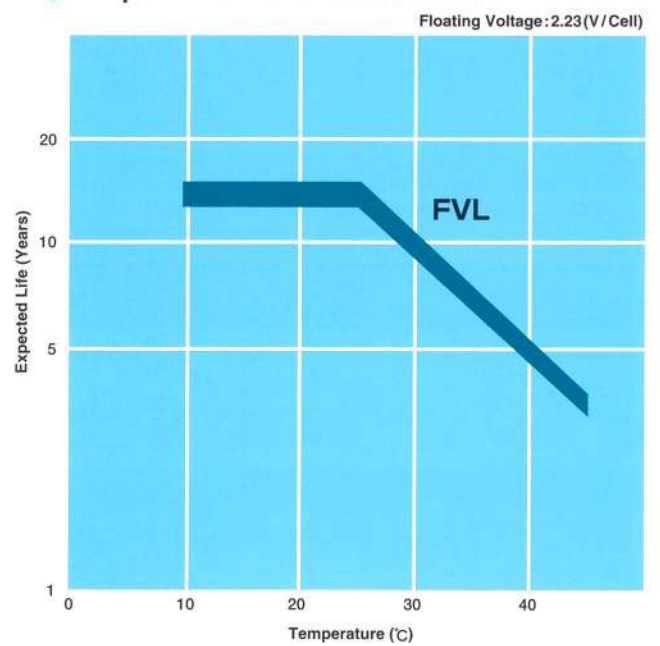



Memo



A series of horizontal dashed lines for writing a memo.

Safety Precautions

- Carefully read the operation manual before using the battery.

Danger

- The room where the battery is installed must be ventilated so that the maximum hydrogen concentration is not more than 0.8%. Storage batteries generate hydrogen gas which may cause explosions.
- Do not install the battery near flames or in areas with poor ventilation where hydrogen concentration is 0.8% or higher. Otherwise, it may result in explosions and fire.

Caution

- The temperature range for using the battery is -15°C to 45°C. Using the battery out of this temperature range may cause deterioration to, or damage the battery by freezing or overheating.
- Do not use the battery under direct sunlight. It may damage battery components.
- Do not allow water to contact the battery. It may damage the battery, cause fire, or corrode the battery terminals and connector plate.
- Do not use the battery near sources of heat. It may damage the battery or shorten its life.
- Do not use the battery in dusty areas. It may cause the battery to short-circuit.
- Charge the battery under the charging conditions specified by Furukawa Battery. Charging the battery under other conditions may prevent full charge; cause the battery to leak, become hot, or explode; or lower performance and shorten the life of the battery.
- Do not install the battery so that it leans downward 90° or more (i.e., beyond the horizontal) from the upright position with the terminals on top. It may cause leakage of the electrolyte.
- The discharge current of the battery must be within 1 minute or less at 3C(A), and 5 seconds or less at 6C(A). Any duration beyond this range may damage the battery.
- The battery should be checked regularly, in accordance with local obligation or governmental regulations required locally. If it is found that battery parameters are out of the ranges specified in the operation manual, solve the problem according to the steps presented in the manual. The usage beyond range specified in the operation manual may damage or burn the battery.



ISO9001 Certified
JQA-1395



ISO14001 Certified
JQA-EM0461

For More Information, please contact.

FB THE FURUKAWA BATTERY CO., LTD.
<http://www.furukawadenchi.co.jp/>

Overseas Operations Division

2-4-1 Hoshikawa, Hodogaya-ku, Yokohama, Kanagawa Prefecture 240-0006 Japan

Phone: 045-336-5063

Fax: 045-333-3411

• The Furukawa Battery Co., Ltd. reserves this right to change the data and specification in this brochure without prior notice.

For further details, do not hesitate to contact us at the address above.